



Dedicated Powder Tools

No mess, no waste.

Dedicated Tools

How to improve workflow of the whole printing process in SLS technology ?

Based on the clients reviews, we designed dedicated tools to make your work with powder safe, easy and fast.

LESS WASTE



Saving time and powder

CLEANER WORKSPACE

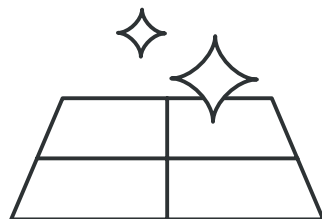

Less cleaning, more effectivity

BETTER WORKFLOW



Up to 2x faster on print preparation

ALWAYS READY

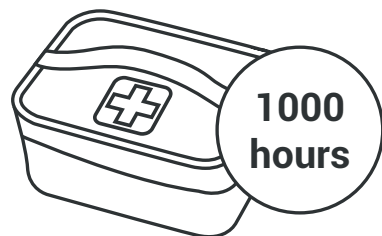

Includes wires, bulbs and lubricants





| Clean & Easy

In the Dedicated Set of Accessories you will find:

- **Elementary tools kit** - needed equipment for the whole printing process, from the initial startup to the post processing
- **Sinterit Funnel** - for easier control of the poured powder stream. Nothing falls outside the work area. No loss, no mess.
- **Powder Tools** that guide you with filling the printer with powder, and removing the cake.
- **Powder Trowel** that allows you to perfectly compact the whole powder in the feed bed.
- **Foldable Tray** - your movable working space to deal with powder and to keep process clean.
- **Service Kit** - set of servicing parts, everything you need to work for 1,000 hours.
- **Document binder** - to keep all manuals at one place.

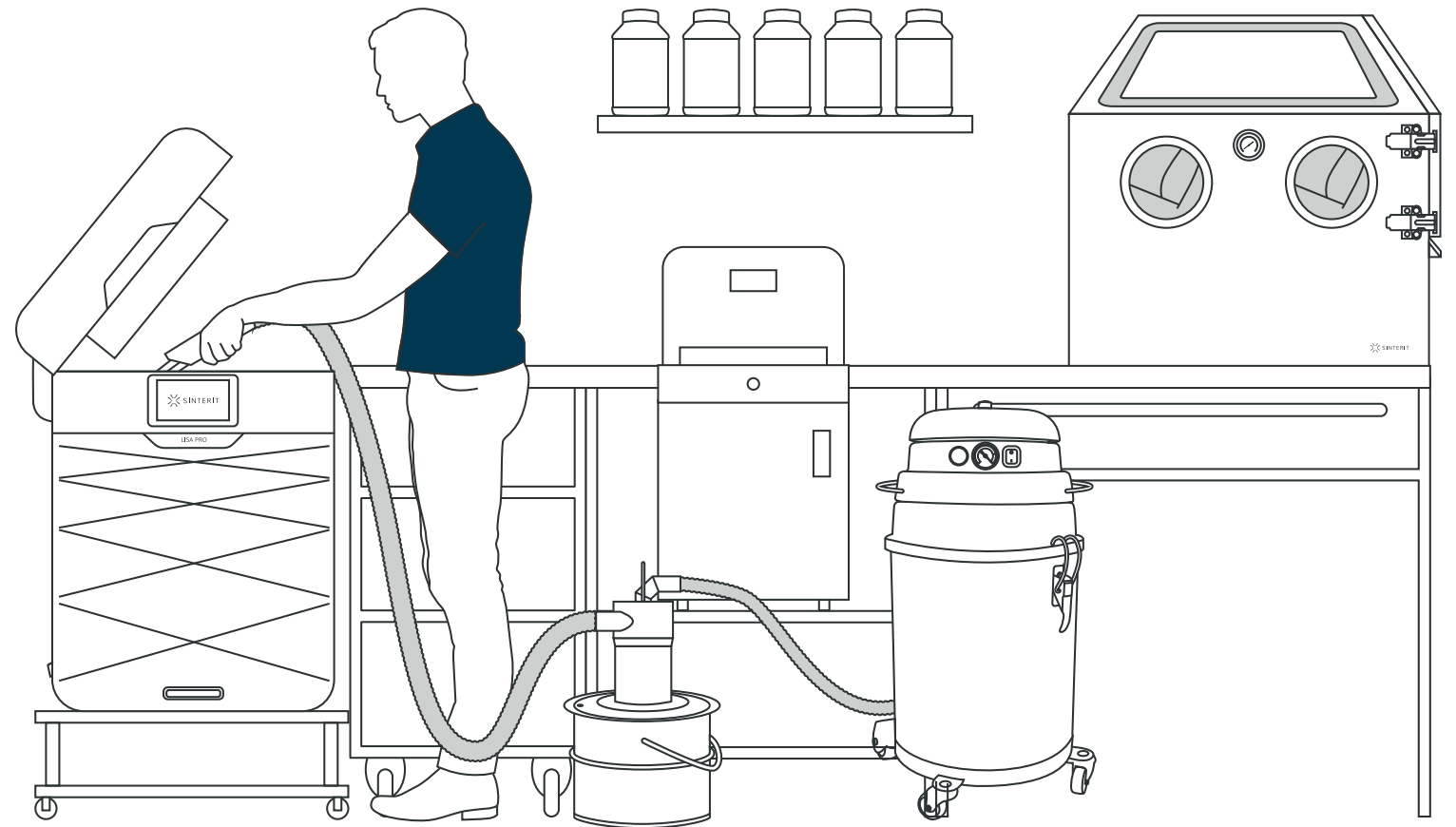



Elementary Powder tools

Everything you need to work at each stage of the printing process



Powder management

Required to fill the printer with powder and take out the print.

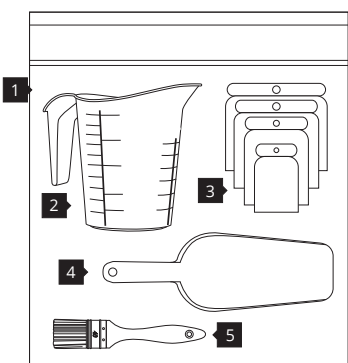

1. String purse / 2. Measuring cup / 3. Scrapers / 4. Scoop / 5. Brush

Personal protection

Always useful when handling with low granulation powder.

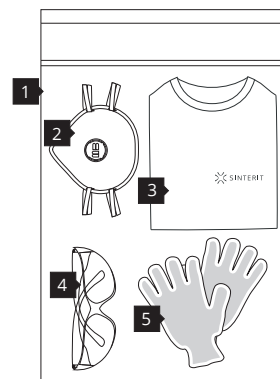

1. String purse / 2. Protective dust mask / 3. Branded T-shirt / 4. Protective glasses / 5. Protective gloves

Post processing

To help you clean your printouts from the remaining powder.

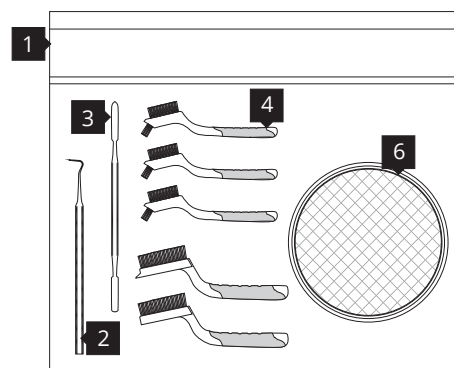

1. String purse / 2. Stainless steel probe / 3. Metal spatula / 4. Small brushes / 5. Large brushes / 6. Metal strainer





Powder Funnel



Powder management tool

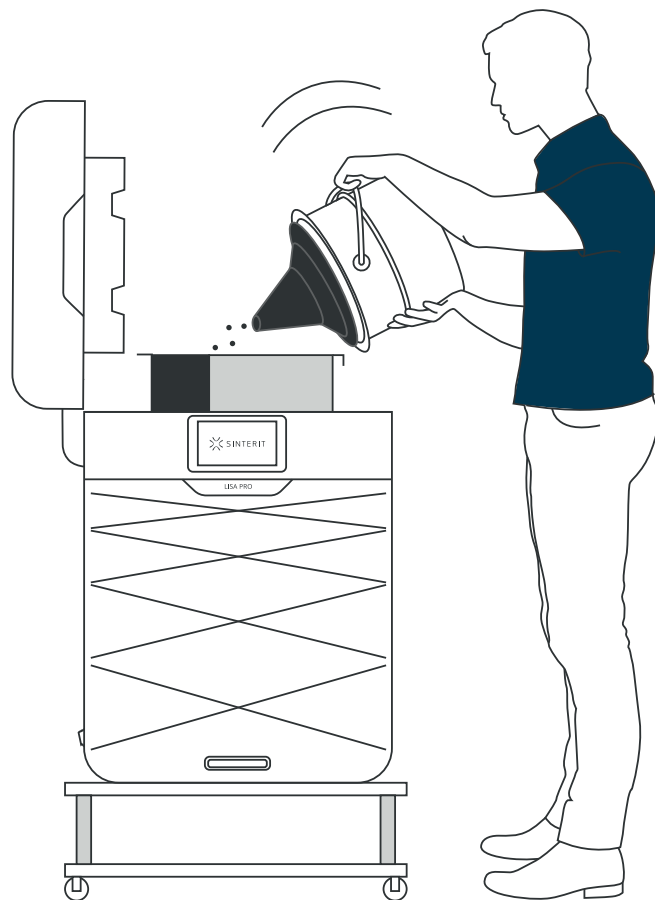

Features:

- Allows you to fill the printer without spraying the powder in the air.
- Makes the measurement of the needed powder easier.
- Keeps the filling process clean.
- Makes powder management easier.
- It is compatible with the new powder container, Sieve, cleaning station, and powder separator - our new powder management system.

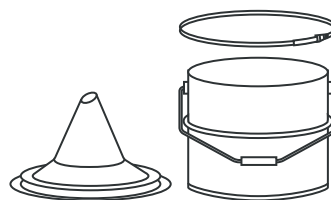

It consists of a bucket, a rim and a funnel.

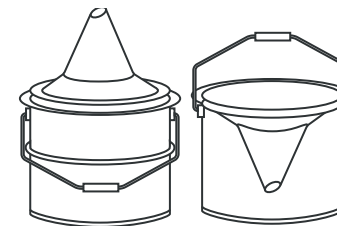

It can be directly used to backfill the printer with powder.

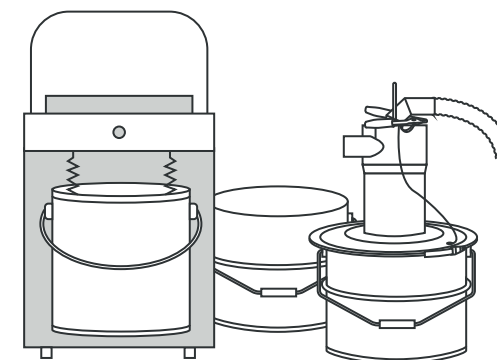

It is matched with other elements of the Sinterit system.



Sinterit Trowel

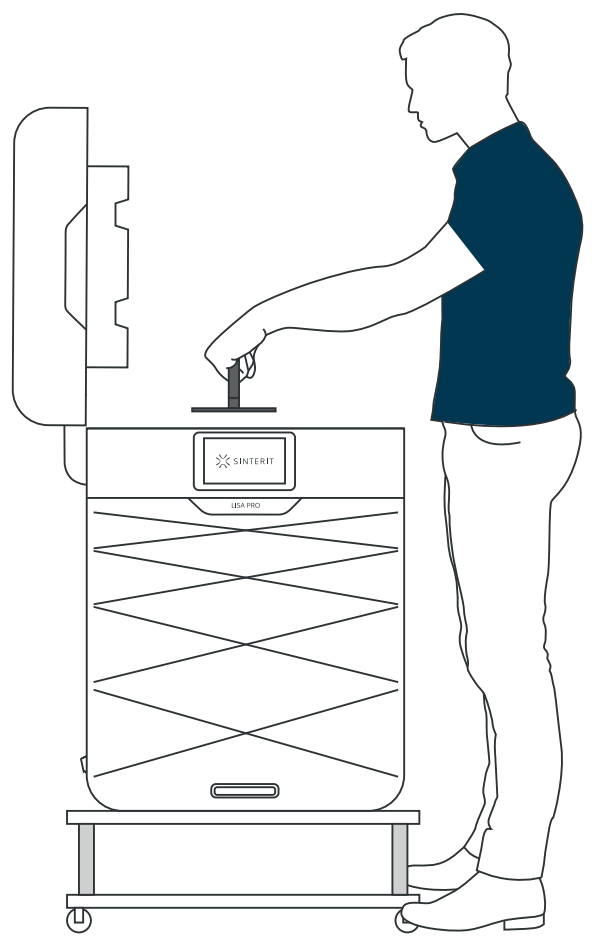
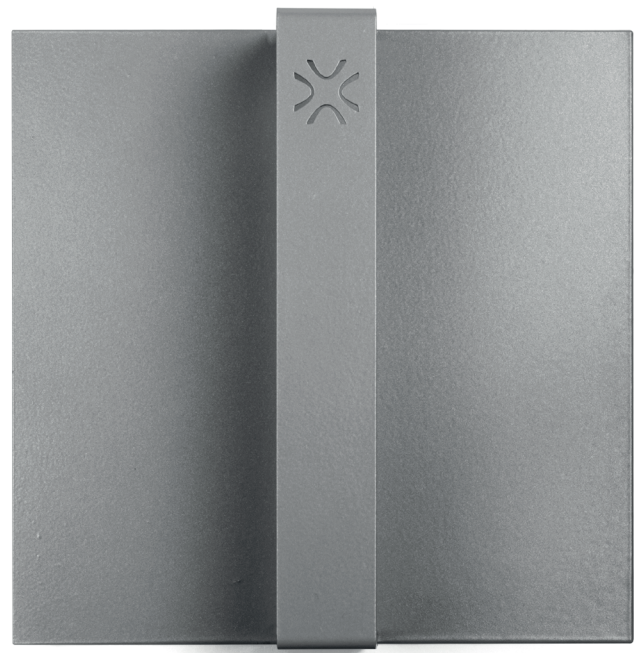

Features:

- Perfectly fits to the feed bed
- Uniform powder tamping in one move
- Uniform pressure distribution
- Proper powder density for perfect printouts

Easy & effective
powder tamping

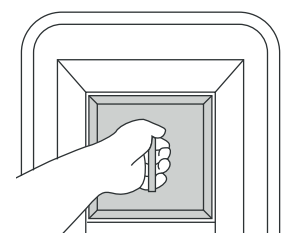

Accelerates the tamping process. All in one move.

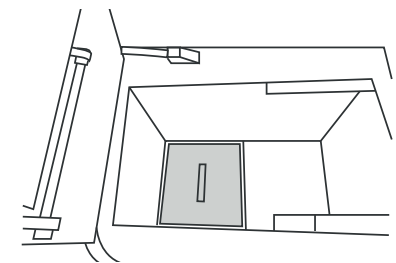

Designed to fill the feed bed completely.

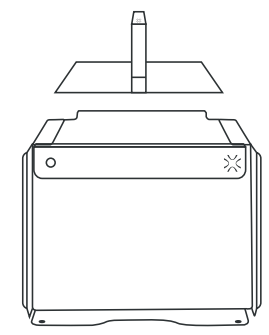

Prevents powder dust from escaping while carrying the printouts (cake).



IO Box Powder Tool



Clean & easy filling
and unfilling the printer.

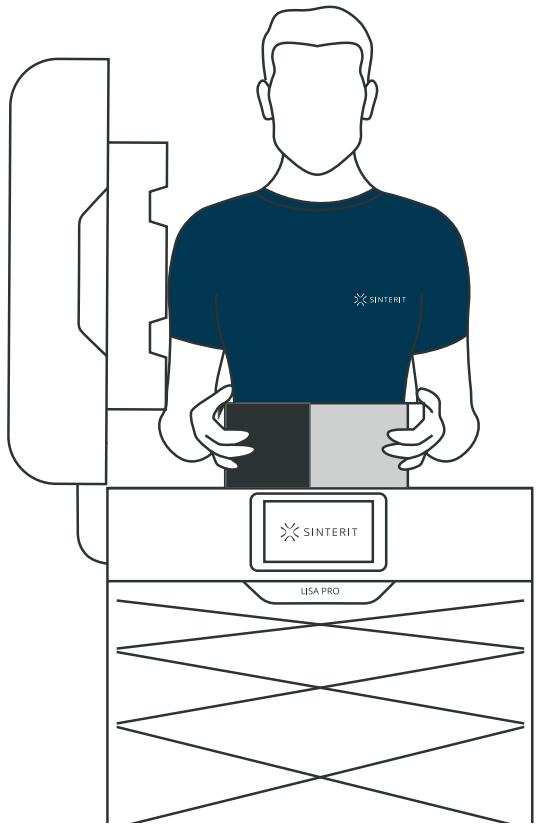

Features:

- Easy and clean printer filling
- Protects the linear guides and pyrometers from unwanted dust
- Designed for putting the powder IN (filling) and taking the print OUT (for post-processing)
- Easy taking out the print
- Perfect fit for the printer
- Fits into the feed bed

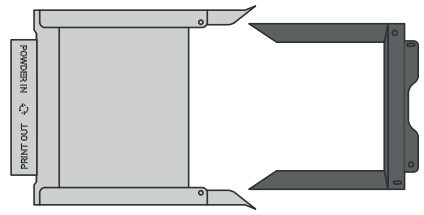

It consists of two elements.

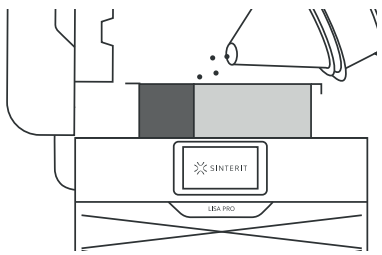

It guarantees the cleanliness of the backfilling process.

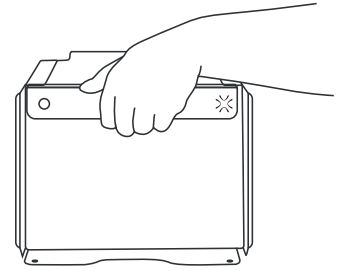

Double handed use makes extracting printouts from the printer secure.



Start New Print
Clean Printer
Advanced Mode
About



IO Box TWO functions tool

Tool is designed in a way that helps you to fill the printer with powder in an easy and clean way.

When you rotate it, it will turn into a tool for taking out the printed “cake”.

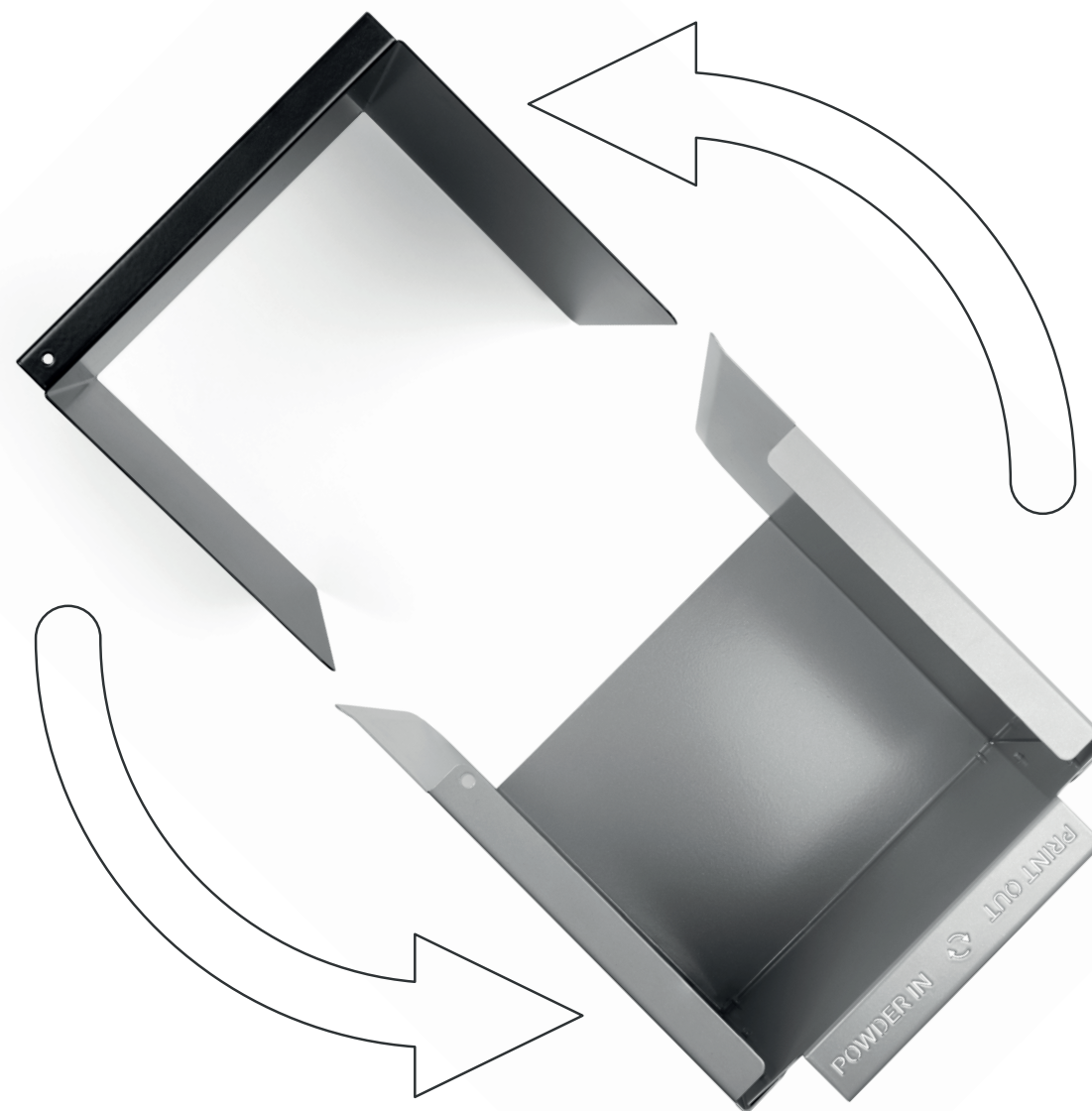
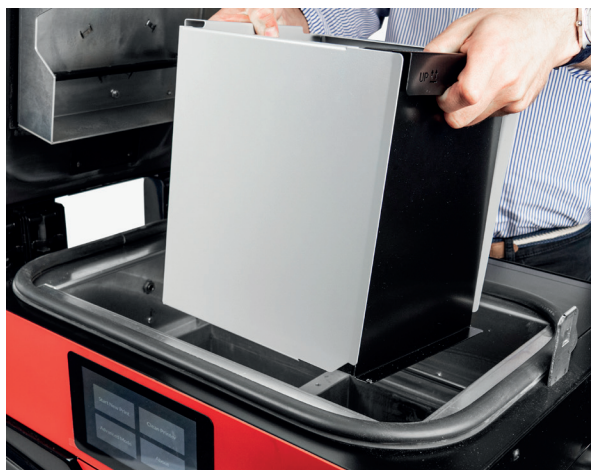



Sinterit Foldable Tray

Your movable working space
to deal with powder

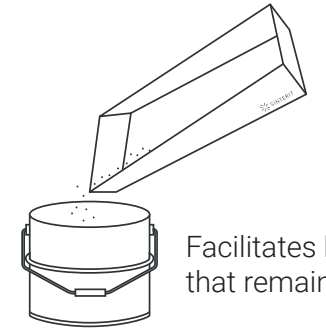
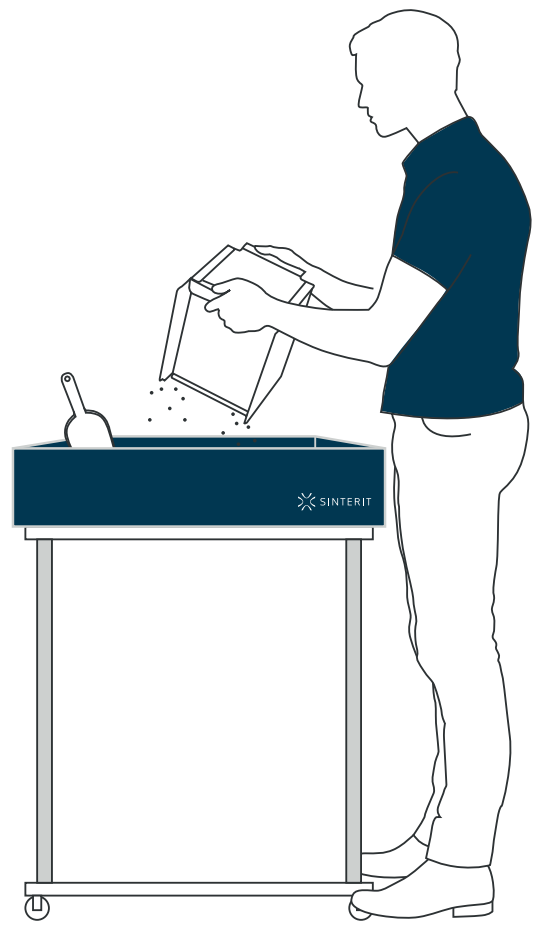

Facilitates handling the powder
that remains after printing.

Features:

- Your workspace for cleaning the printouts that helps to keep the leftover powder in one place
- Optimal size for printouts initial post-processing
- A storage space for your tools
- Can be used as a powder chute
- Foldable & light
- Easy to be cleaned





Sinterit Service Kit

Contains a stock of servicing items necessary for preparation for work and servicing the machine.

Set contains:

- 3 x recoater cord for LISA PRO or LISA - each lasts for 200 hrs
- 2 x Silicone oil
- Set of cleaning wipes for glass elements
- 16 x heaters supply for at least 1000 hours of printing
- Cotton cloths for additional dry cleaning

Thanks to the handle, the container is easy to carry or hang. It can be machine washed.

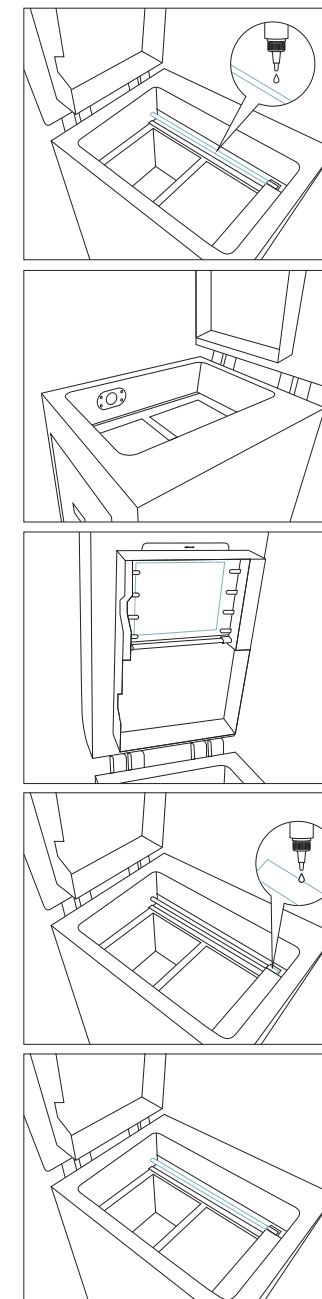





Dedicated Tools



Contains **all you may need** to print fast, safely and keep the working area clean with Lisa and Lisa PRO printers.

All the elements are **compatible** with the Sinterit ecosystem.

For more information, please contact your local distributor or simply visit [sinterit.com](https://www.sinterit.com)





Sinterit sp. z o.o.
ul. Nad Drwiną 10 bud. B3
30-741 Krakow
Poland
www.sinterit.com

Find a distributor in your country:
www.sinterit.com/our-distributors/

If you have any questions, simply ask us at:
contact@sinterit.com or call +48 570 967 854

How it works?

Visit our Instagram or YouTube profile:

 [@sinterit_3d](https://www.instagram.com/sinterit_3d)  [sinterit.com/yt](https://www.youtube.com/sinterit.com/yt)

